

RADIANCE™

SUNLIGHT READABLE LED DISPLAYS

RAD-220AUWS+1

PRODUCT DATA SHEET – PAGE 1 OF 7

08/17/10

22.0" WSXGA+ LED BACKLIT TFT DISPLAY SOLUTION

SOLUTION OVERVIEW:

The **RAD-220AUWS+1 Display** consists of the 22.0" AUO G220SW01 V0 WSXGA+ TFT LCD Display complete with a high performance LED backlight.

Display Features:

- Sunlight readable LCD panel with high efficiency solid state LED backlight
- **800 cd/m² with 48W**, Sunlight Readable
- Ideal for demanding Industrial, Military and Marine applications, as well as Outdoor Kiosks, POS, and Gas Pumps
- Highly reliable LED backlight configuration provides light-source redundancy
- Includes LED drivers with ultra-wide dimming range
- RoHS Compliant

Sunlight Readability/Cool Operation



SOLUTION INCLUDES:

<u>QTY</u>	<u>P/N</u>	<u>DESCRIPTION</u>
1	ACD-AU220-1935	22.0" WSXGA+ TFT LCD Display with High-Performance LED Backlight
2	ACI-E105280-1942	LED Driver
2	27-R0061	Input Cable Assembly

Also available: LCD Controller, LVDS Cable, OSD and Cable.

TABLE OF CONTENTS:

<u>DESCRIPTION</u>	<u>PAGE(S)</u>
Solution Overview	1
Display Specifications	2
Backlight Specifications	3
LED Driver Specifications	4 - 6
Application Notes	7

DISPLAY SPECIFICATIONS

Panel Manufacturer	AUO
Manufacturer's Part Number	G220SW01 V0
Size	22.0"
Resolution	WSXGA+ 1680(x3) (H) x 1050 (V)
Contrast Ratio	1000:1 (typical)
Pixel Pitch	0.282 (per one triad) x 0.282 (mm)
Operating Temperature Range	0 to +50°C
Response Time, Rising + Falling	20ms (typical)
Viewing Angle	178° (Horizontal), 178° (Vertical)
Panel Power (not including backlight)	6.5W
Interface	LVDS Dual Channel
Display Colors	16.7M colors 6-bits (6-bits + HiFRC)
Surface Treatment	Anti-Glare
Surface Treatment, Hardness	3H
Display Mode	Negative

For complete LCD specifications (standard panel), refer to AUO G220SW01 V0 datasheet (document version 0.1 dated 2008/09/02).

BACKLIGHT SPECIFICATIONS
MAXIMUM RATINGS*

Symbol	Parameter	Value	Unit
Top	Operating temperature of display (center of panel surface)	0 to +50	Deg-C
Tled	Operating temperature of LED edge light (light rail contact)	-20 to +60	Deg-C
Tstg	Display storage temperature	-20 to +70	Deg-C
Ifwd	LED forward current	310	mADC

* Maximum Ratings are those values beyond which damage may occur.

PANEL/BACKLIGHT OPTICAL CHARACTERISTICS

Ifwd = 47mA per LED bank, 6 banks per rail, 2 rails per display (LED rail ACR-0866-1932), Ta = +25Deg-C, LCD active

Symbol	Parameter	Test Conditions	Min	Typ	Max	Unit
Bp	Panel Brightness		720	800	880	cd/m ²
X	White X coordinate			0.309		-
Y	White Y coordinate			0.376		-

LED EDGE-LIGHT ELECTRICAL CHARACTERISTICS

Ifwd = 47mA per LED bank, 6 banks per rail, 2 rails per display, Top = +25Deg-C

Symbol	Parameter	Test Conditions	Min	Typ	Max	Unit
Vfwd	LED rail forward voltage drop		77	86	95	Vdc

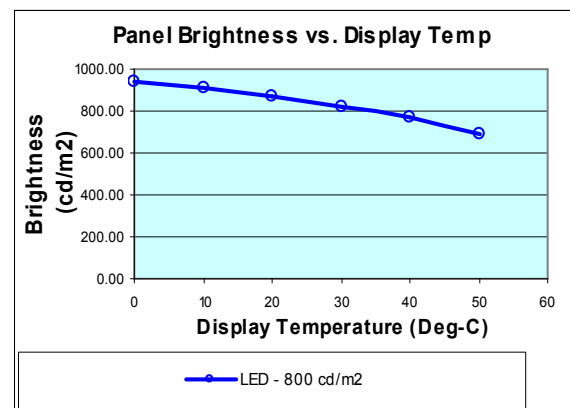
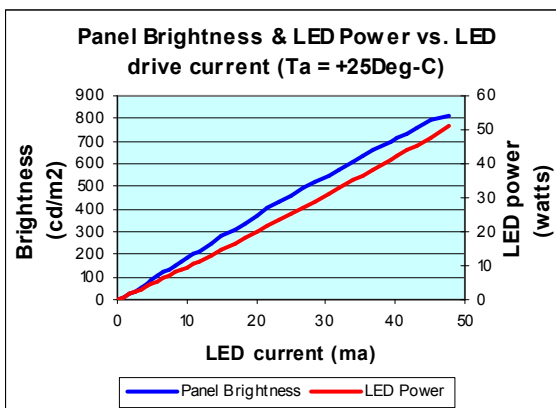
TYPICAL LCD/LED BACKLIGHT PERFORMANCE GRAPHS

LED DRIVER SPECIFICATIONS

I-DRIVE, 30.0 WATT LED DRIVER

(Single Channel 105V, 0-280mA)

GENERAL DESCRIPTION

The ACI-E105280-1942 represents the 5th generation of I-Drive technology used for powering LED backlights.

Operating as a true constant current source and capable of driving up to 40 LEDs in series. This driver provides a complete integrated solution that is regulated over an input range of +10V to +15V.

Simple to connect and operate, this driver solution is capable of providing precise control to support dimming applications with a minimum of 3000:1.

This unit features enable and intensity control inputs.

MECHANICAL/ENVIRONMENTAL

Weight = 33.2 grams

Altitude = 35,000 ft max.

Humidity < 95% non-condensing

Size (L x W x H) = 3.25 IN x 2.00 IN x 0.47 IN

PCB thickness = 0.062 IN

Mounting Holes = 0.128 IN diameter (X2)

Input Power & Control Connector = CON1

LED Output Connector = CON2

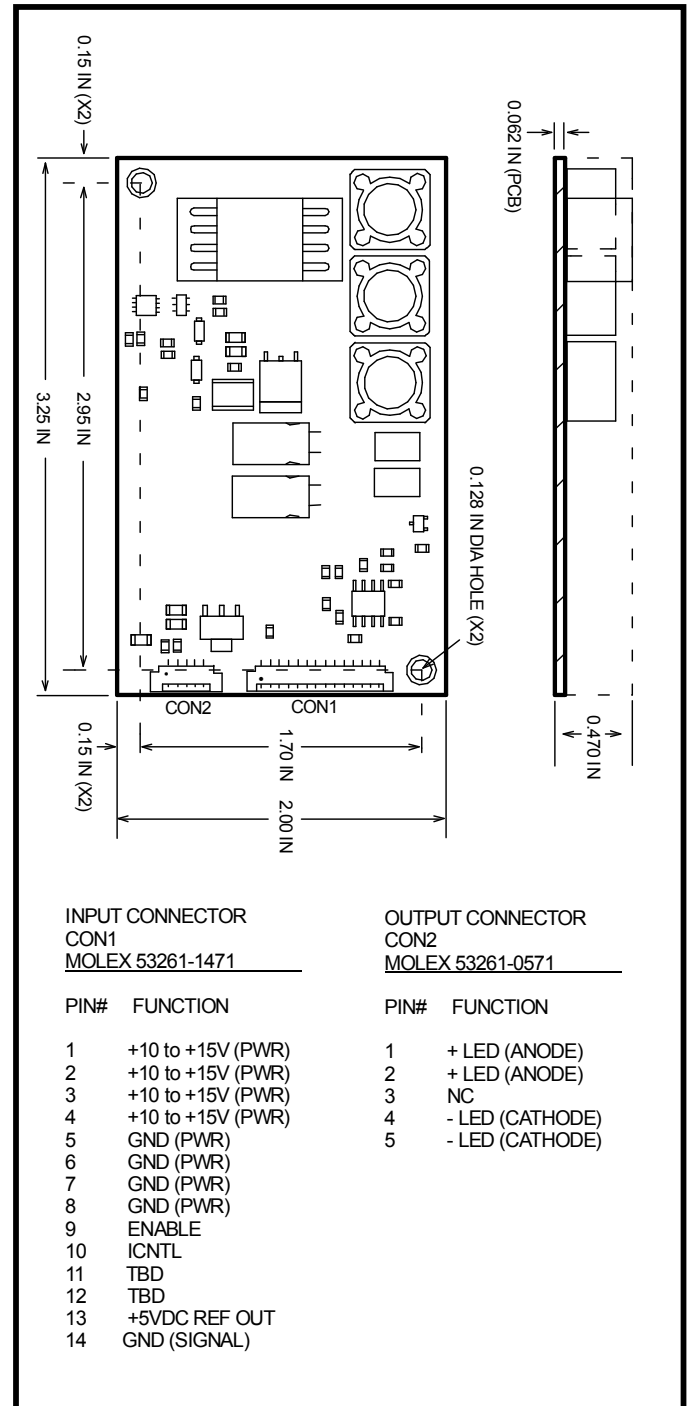

LED DRIVER SPECIFICATIONS
MAXIMUM RATINGS*

Symbol	Parameter	Value	Unit
Vin	Supply Voltage (Referenced to Ground)	-0.7 to 20	Vdc
Vip	Voltage applied to any Input Pin (Referenced to Ground)	-0.7 to 5.7	Vdc
Iop	Current sourced or sinked from any Output Control Pin	+/- 10	mAdc
Pin	Input Power (DC Input Voltage x DC Input Current)	34.7	W
Top	Operating Temperature (Still air ambient around Driver)	-30 to +85	°C
Tstg	Storage Temperature	-40 to +105	°C

*Maximum Ratings are those values beyond which damage to the driver may occur.

RECOMMENDED OPERATING CONDITIONS

Symbol	Parameter	Min	Max	Unit
Vin	Supply Voltage (Referenced to Ground)	10.0	15.0	Vdc
Vf	Series Connected Cumulative LED Forward-Drop Voltage	30	105	Vdc
Icntl	LED Intensity Control Voltage	0.5	4.5	Vdc

ELECTRICAL CHARACTERISTICS

Vin = +12V, Vf = 105Vdc, Icntl = +4.5V, Enable = +5V unless otherwise specified

Symbol	Parameter	Test Conditions	Min	Nom	Max	Unit
OCV	Open Circuit Voltage	No Load	133	140	147	Vdc
Iout	Output Current		252	280	308	mAdc
Iadj	Nominal Output Current Adjust Range	Icntl(Pin 10)= +0.5V to +4.5V	0		280	mAdc
ENoff	Enable Control, Unit Off				0.5	Vdc
ENon	Enable Control, Unit ON		2.0			Vdc
+5Vref	+5V Output Reference Voltage	1K Ohm Load to Ground (Pin 13)	4.75	5.0	5.25	Vdc
Iin	Input Current Draw			2.9		Adc
Iind	Input Current Draw (Disabled)	Enable (Pin 9) = 0V			0.06	Adc
Eff	Electrical Efficiency		85			%

LED DRIVER SPECIFICATIONS

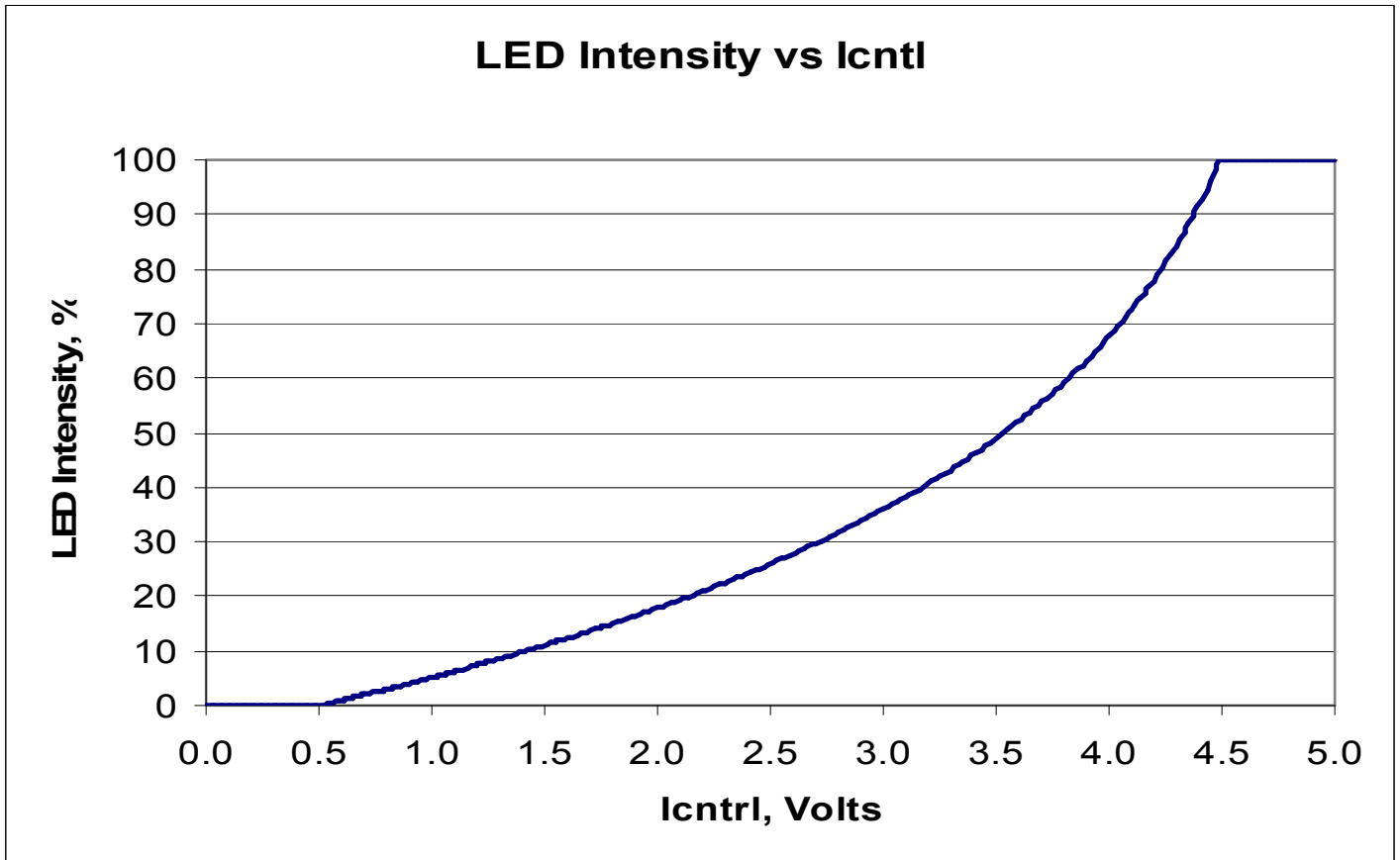

APPLICATION NOTES

Connection Diagram:

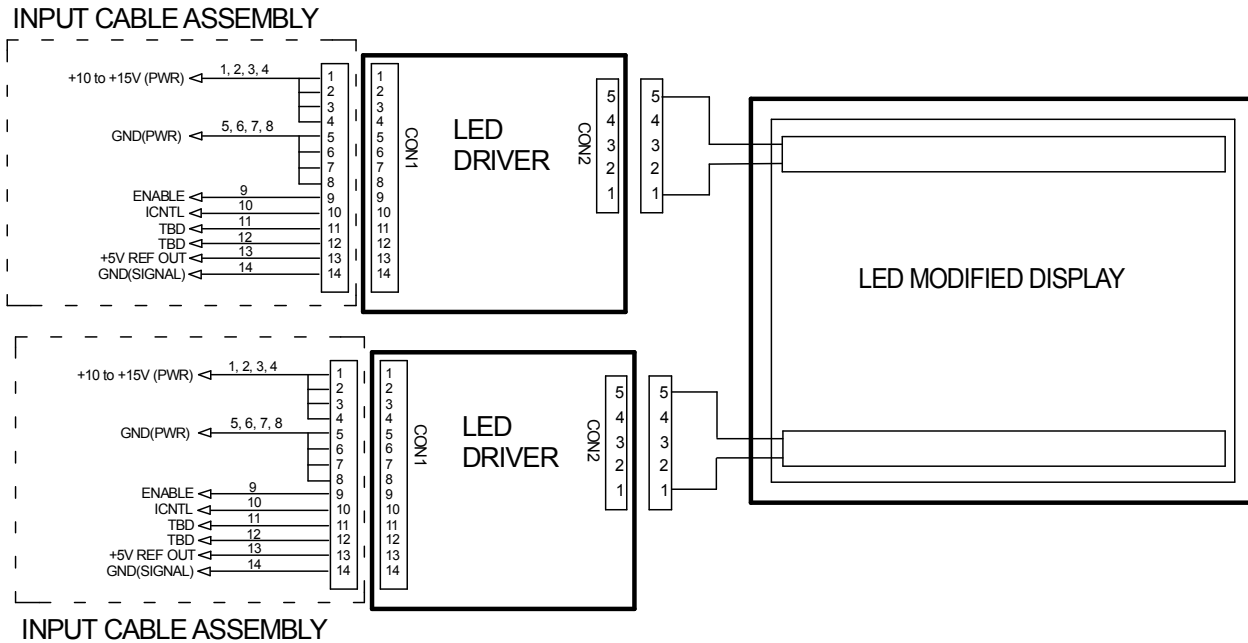

1. Tie the +10 to +15V (PWR) leads together from both drivers.
2. Tie the GND (PWR) leads together from both drivers.
3. If using the Enable line, tie the Enable leads together from both drivers.
4. If Enable line is not being used, it may be left electrically floating.
5. If dimming is not being used, tie the ICNTL lead to the +5V REF OUT lead together for each driver.
6. If dimming is being used, tie the ICNTL leads together from both drivers. A 10K OHM Potentiometer is recommended.
7. If the +5V REF OUT is being used for the high side of the Potentiometer, use only one of the +5V REF OUT leads.

Connecting 10K Ohm Potentiometer used for Dimming

